

# 2 in 1 Mug Heat Press Machine Manual

## Model No.:SKVA1059

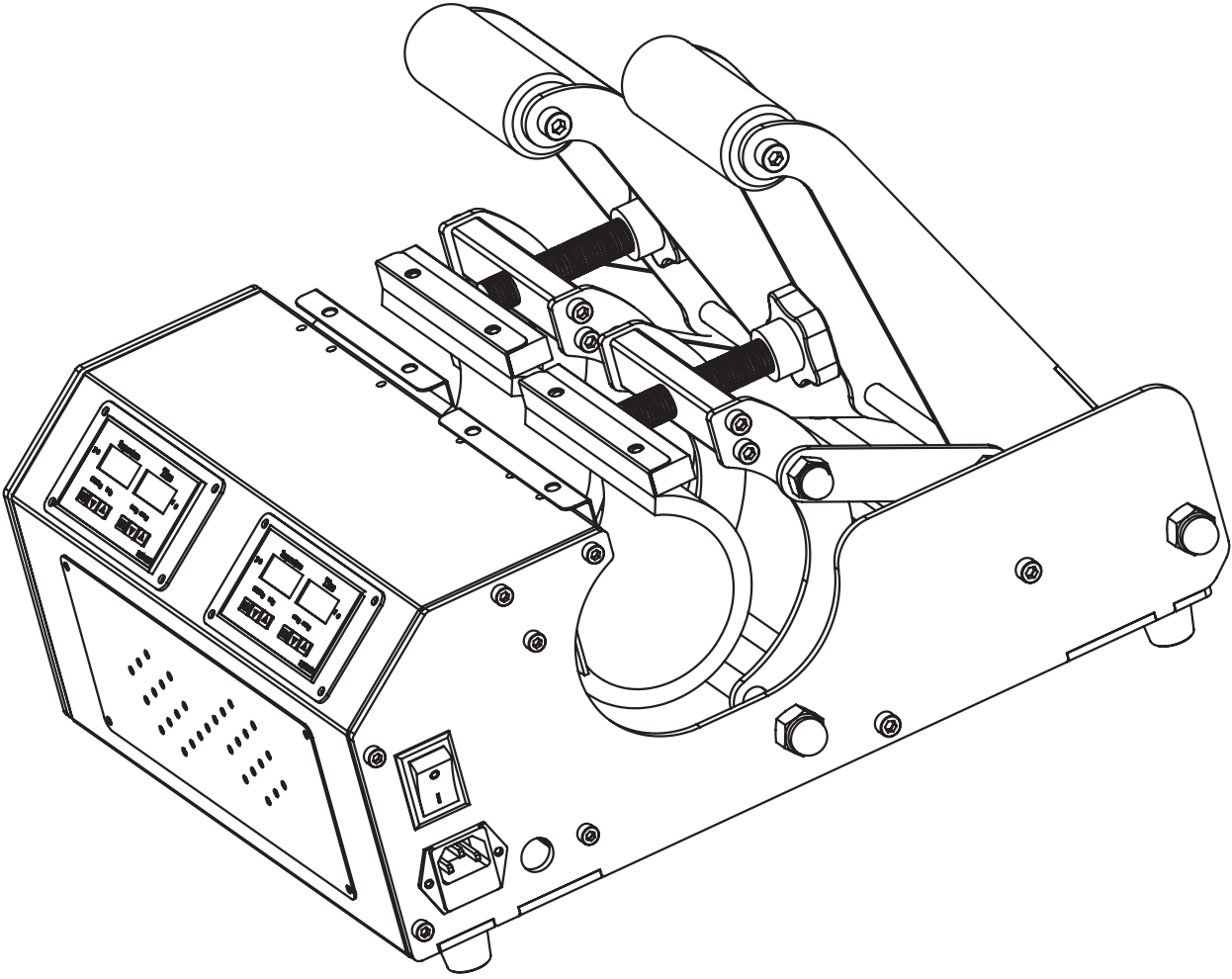

I. Assembly Drawing	-----	2
II. Technical Parameters	-----	2
III. Maintenance	-----	3
IV. Trouble Shooting For Transfer Print Quality	-----	3
V. Operating Process	-----	3-4
VI. Circuit Diagram	-----	5
VII. Explosion View	-----	6-7

# I. Assembly Drawing

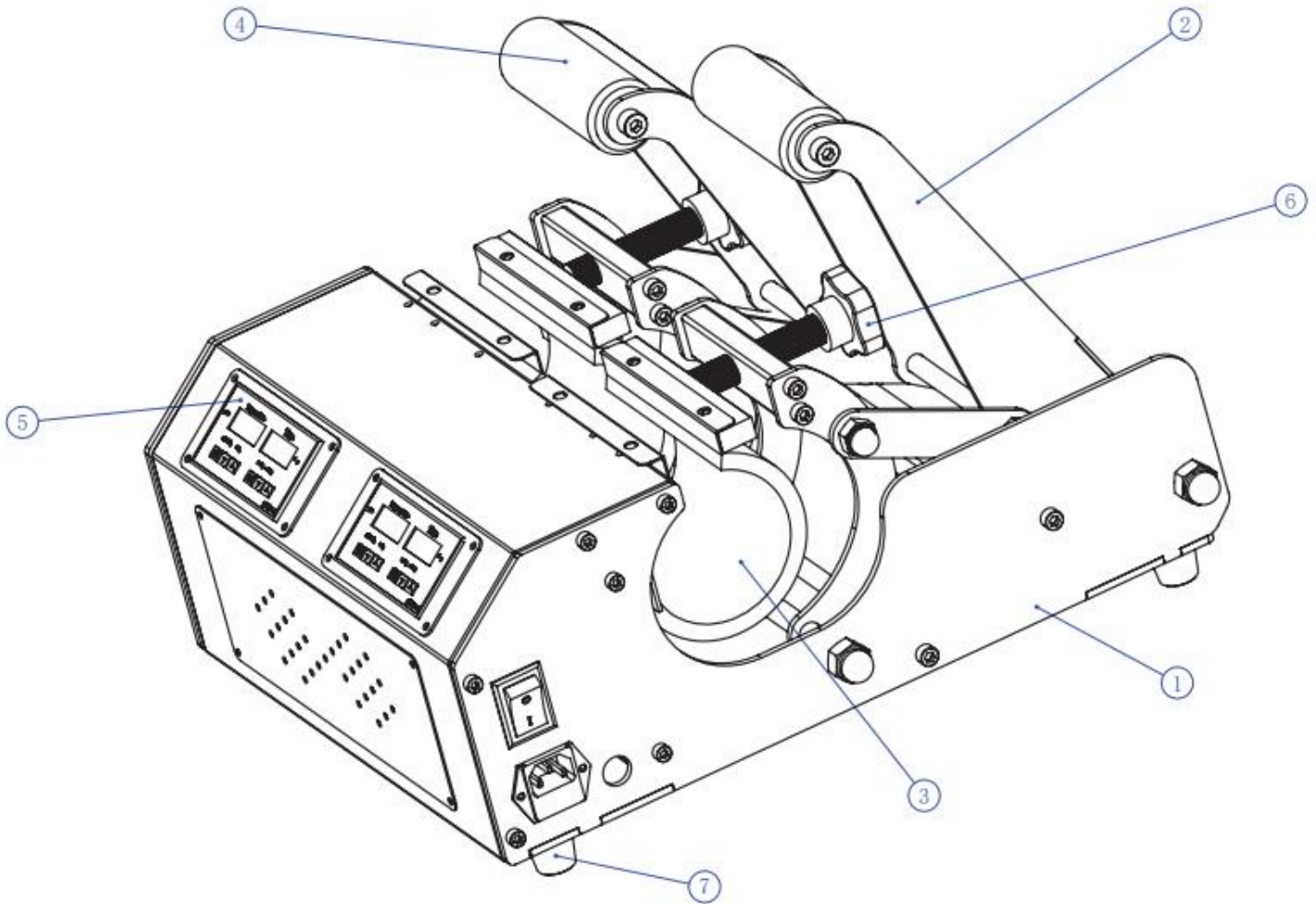

1.Rack Assembly	2.Handle Bar Grip	3.Mug Heat Element	4.Handle Assembly
5.NTTH-2000 controller	6.Adjuster Hand Wheel	7.Machine Feet	

# II. Technical Parameters

Machine Type:Manual, Easy heater exchange  
Mug Heater: 11OZ  
Controller: NTTH-2000 Digital Controller&temperature controller  
Maximum Temp: 255°C(491°F)  
Temperature Accuracy: ±5 C  
Time Range:120-220 seconds  
Power: 2\*300W=600W  
Current: 2.8A/5.5A  
Voltage: 220V/ 110V  
Frequency: 50-60Hz  
Machine Pressure:Adjustable

### III. Maintenance

1. In order to prolong the machine service life, please add the lubrication oil on the joints regularly .
2. Turn off the power before changing spare parts. In order to ensure the accuracy of the parameter of GY-10 controller, please re-set the time and temperature.
3. To avoid damage, please keep the heaters well when change the spare parts.

### IV. Trouble shooting for transfer print quality

1. After changing mug heater, time and temperature showing become abnormal:  
Solution: Reset time/temperature according to the manual
2. If the color is not as bright as photo after printing, please try below ways:  
Solution: A. Adding transfer time. B. Increasing transfer temperature.
3. If the print color is too brown or the transfer paper is almost burnt:  
Solution: Please reduce the setting temperature.
4. If print color is different/ partial transfer effect is not good enough:  
Solution: A. Increase the pressure. B. Extend the transfer time. C. Change the sublimation paper.
5. If the machine is getting abnormal, please contact us to solve the problems.

### V. NTHH-2000 Controller Operating Process

1. Turn on power switch, The temperature and time shows 888, all indicators will be on; then the temperature is show Inp, and the upper limit of temperature is displayed 255/491; time shows “Y” first, then show 0/32, finally, enter into the home screen, temperature display current actual temperature, time display set value, machine temperature rise, OUT lights on using degrees celsius, “ °C “ light on, use degrees fahrenheit, “ °F” light on.

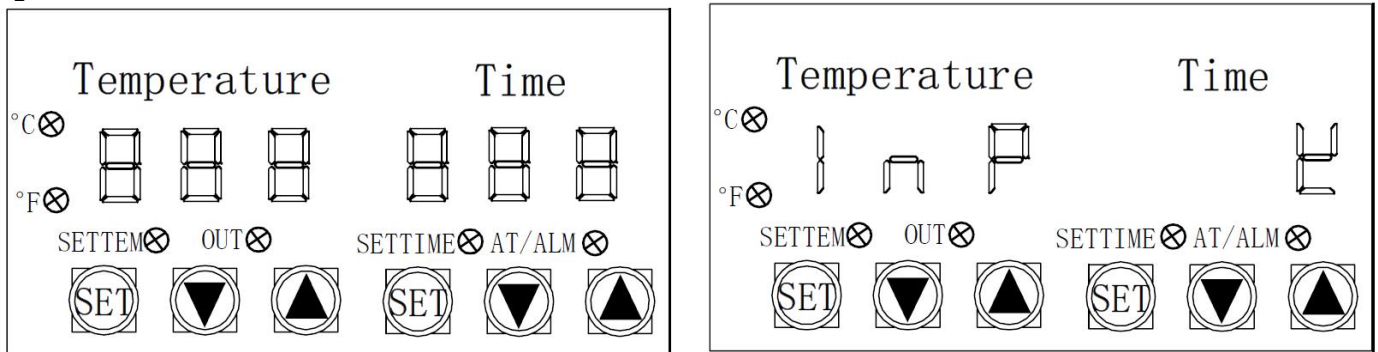

2. Press the temperature SET key,SETTEM light on, Press “▲▼” adjust (The maximum of fahrenheit can setting 491, Celsius can setting 255), then press, SET key again, After the indicator is off, save and exit, show the current temperature. OUT Indicator light on, the machine enter into rise temperature schema. Press the time SET key, SETTME light on, press “▲▼” adjust the countdown time (the time is adjustable from 0 to 999 seconds), press the SETTME key again. After the indicator is off, show the set time value.

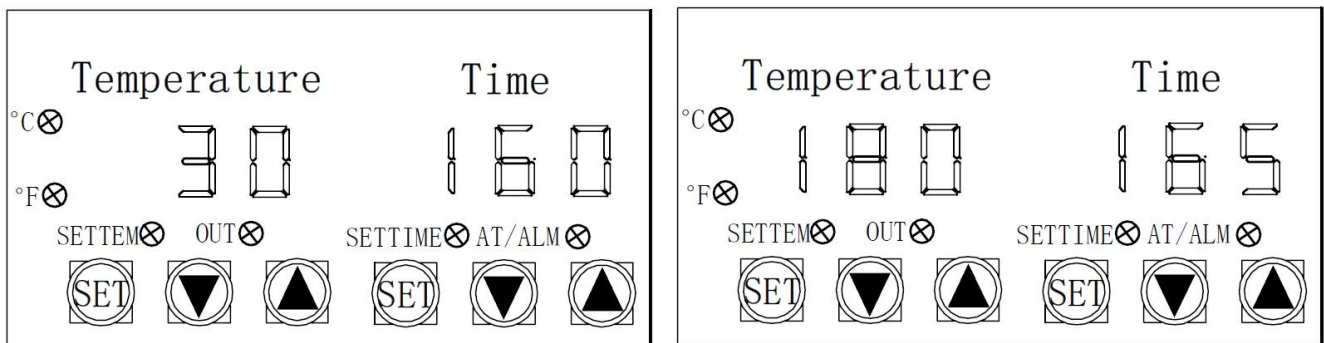

3. Press down heating plate transfer when the heat plate temperature reaches the set value, the left side shows the current temperature, the countdown time is displayed on the right, count down to 0 seconds, AT/ALM indicator light on, the buzzer continuous sound, if not release the sound will not stop, lift heating plate,indicator off, end of the countdown.

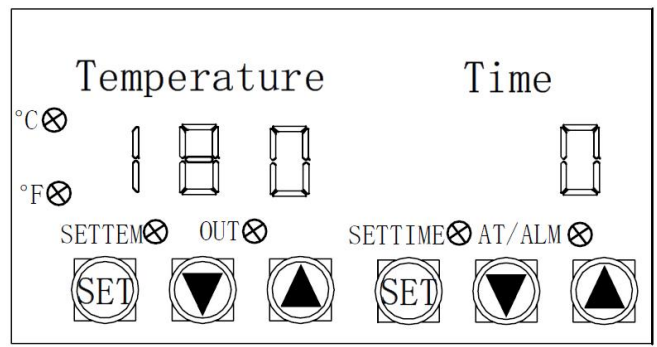
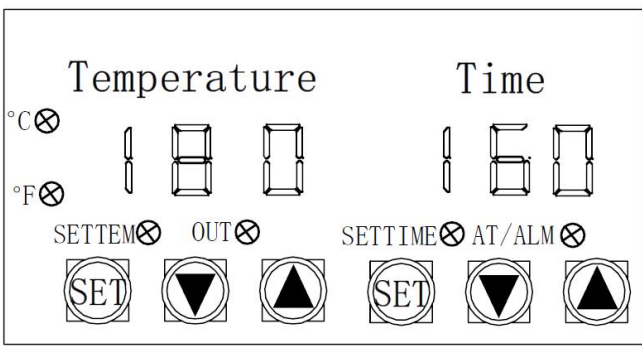

4. Long press the set key on the left side of the thermostat for 5 seconds and enter engineering mode 1 when it is displayed on the left side: When displayed "rt", set the temperature correction value, press "▲▼"adjust; range of correction -199~999; long press the set key for 5 seconds or 30 seconds without operating the key to save and exit engineering mode 1.

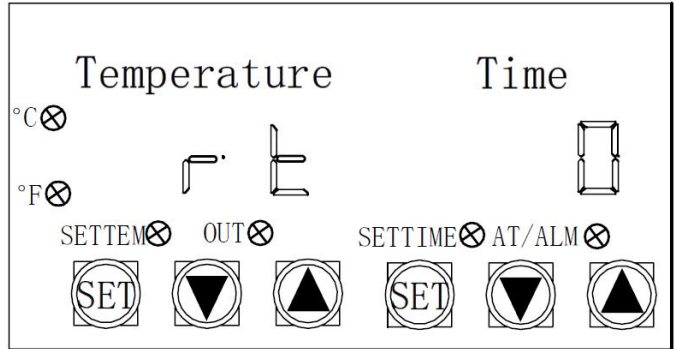
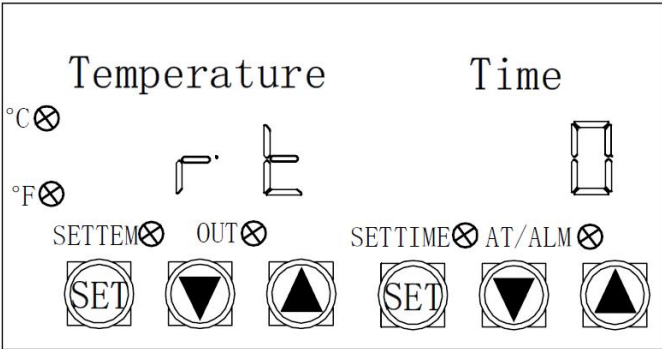

5. Press the "▲▼" temperature controller on the left key at the same time, 1 second to enter Engineering Mode 2: Displayed "LY" 30 press again key to show "LY 88", click the left SET key successively; when shown "CF", press "▲▼"adjust, set temperature unit, press "▲▼" adjust; "CF" set 1 unit, when the "DF" set 1 unit is Fahrenheit "F", set 0 unit is celsius C; Display rL set the lower limit of temperature, display rH temperature upper limit, "C" maximum set 255, "F" SET the maximum to 491. Press the Set key again to save and exit.

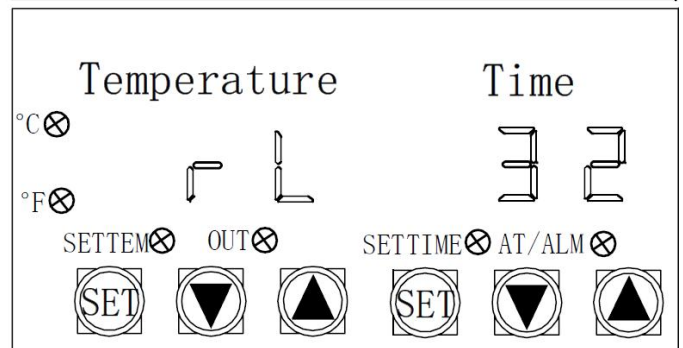
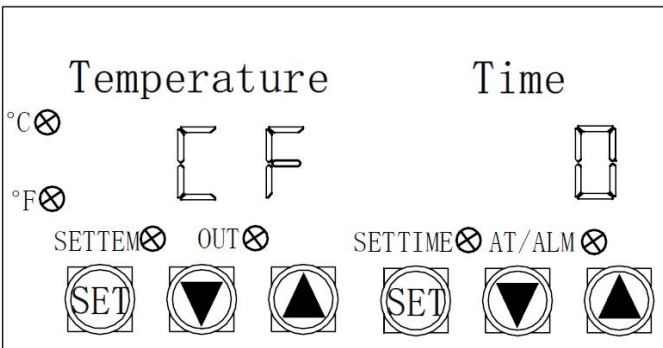
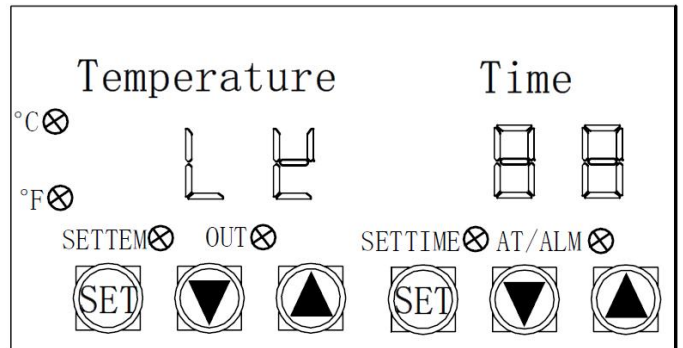
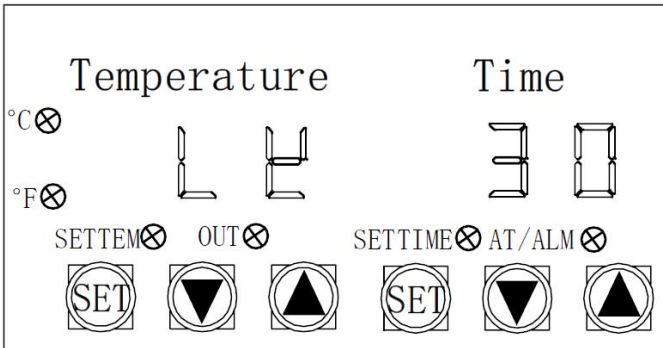

Please contact the supplier before operating the above 4&5 engineering mode.

# VI. Circuit Diagram

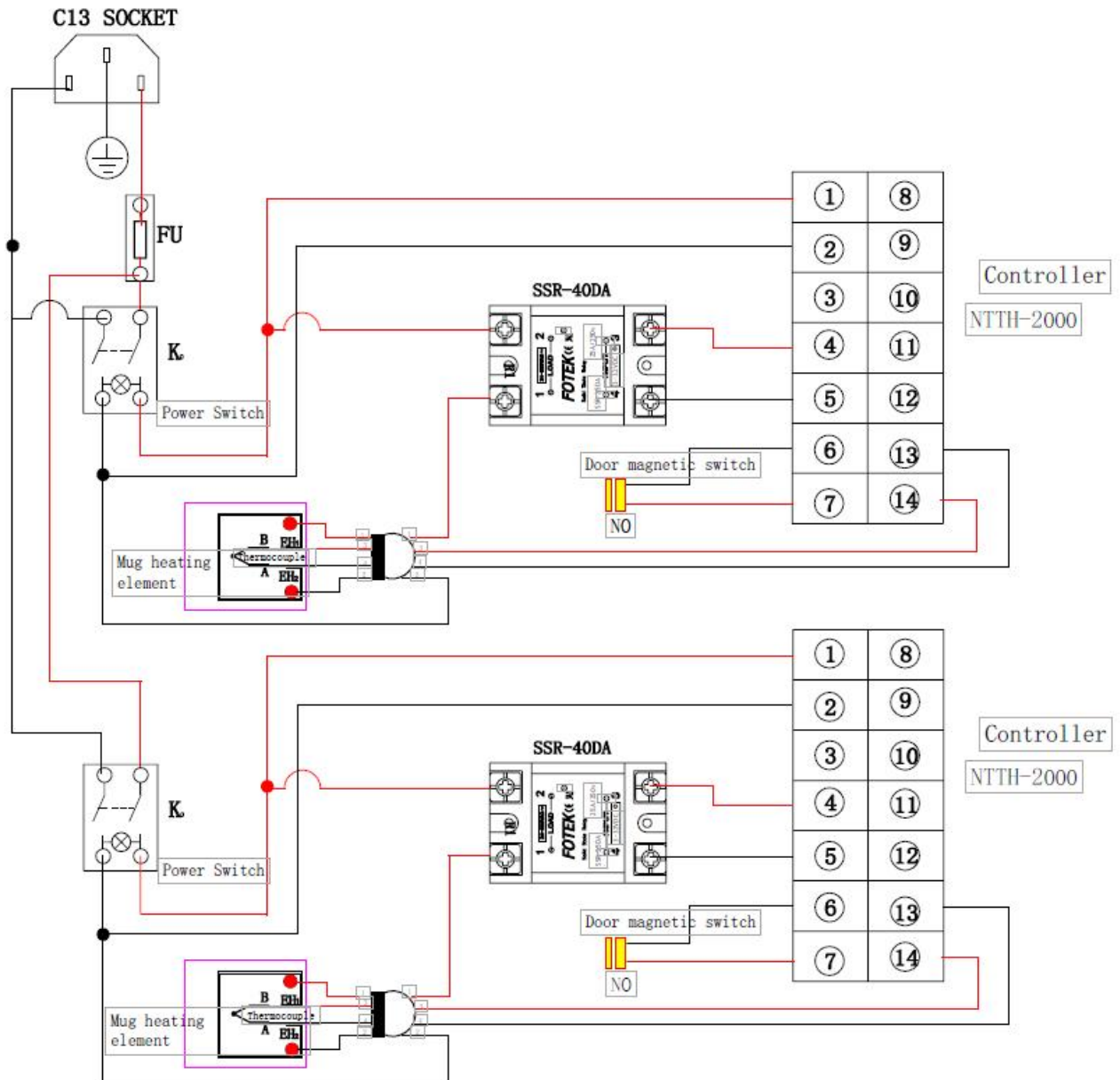

## VII. Explosion View

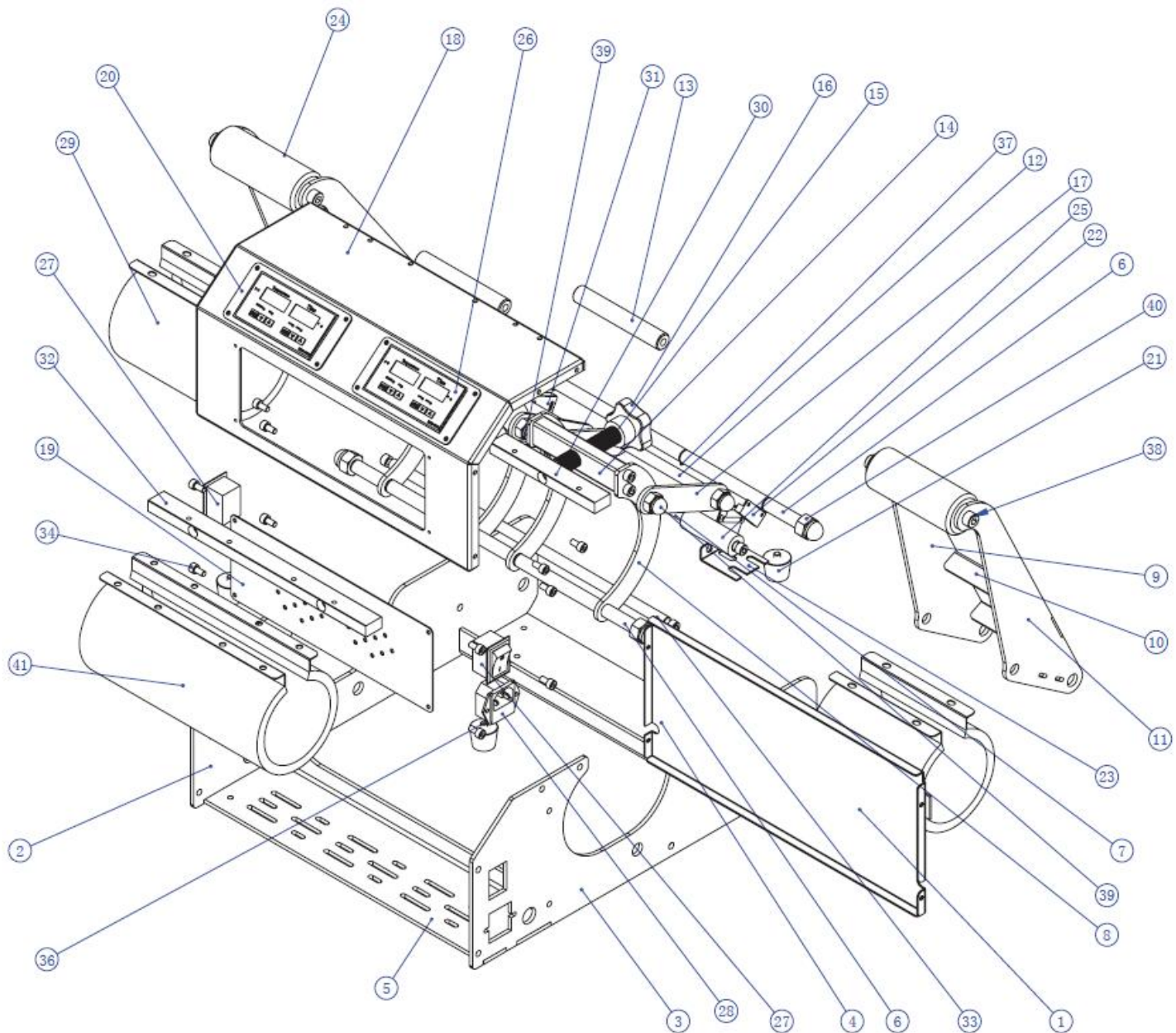

No.	Part Name	Qty
1	Electric box rear baffle	1
2	Left side plate	1
3	Right side plate	1
4	Mug machine foot board	1
5	Mug machine foot board 5- 1	1
6	Chrome rod for cup machine	2
7	Chrome plated rod pole	1
8	Pressure half moon plate	4
9	Cup machine handle plate- 1	2
10	Pressure arm connection plate	2
11	Cup machine handle plate-2	2
12	Middle pole pin	4

No.	Part Name	Qty
22	Door magnetic induction switch	4
23	Magnetic induction switch mounting plate	1
24	Handle Sleeve-long	2
25	Limit rod sleeve	2
26	Temperature table	2
27	Boat shaped switch	2
28	Pins Plug	1
29	Mug heating element 130-235	2
30	Front Pole	2
31	Magnetic induction switch mounting plate	1
32	Front pole	1
33	Lower limit bar	1

13	Handle Bar	2
14	Adjust the pole fixing bar	2
15	Adjusting Screw Rod	2
16	Little five star hand wheel	2
17	Connecting Plate	4
18	Rear strut folding Luan plate-2	1
19	Rear strut folding Luan plate- Electrical box door panel	1
20	Temperature control meter fixed plate	2
21	Machine feet	4

34	Cup heat screwM5x10	11
35	Cup heat screw M6x10	12
36	Cup heat screw M6x16	4
37	12Circlip	4
38	Cup heat screw M8x16	4
39	Round heat nutM10 --N	8
40	Round heat nut M12 --N	4
41	Mug heating element 220-235	1